

# Standard PM Step Motors

## PM42S-048-HHC8

### Model Specifications

Model:	PM42S-048-HHC8
Shaft Length:	12mm
Wire Length:	300mm fly lead (no connector)
Wire Holder:	90 deg. Left
Front Plate:	FPH
Electrical:	24V, 600mA
	Bipolar Constant Current
	8 ohms, MS70M

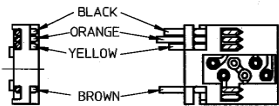

WIRE COLOR CODE

WIRE COLOR	MOTOR
BLACK	A1
BROWN	A3
ORANGE	B1
YELLOW	B3

STEP	COLOR			
	BLACK	ORANGE	BROWN	YELLOW
1	-	+	+	-
2	-	-	+	+
3	+	-	-	+
4	+	+	-	-

SWITCHING SEQUENCE  
(VIEWED FROM MOUNTING SURFACE)

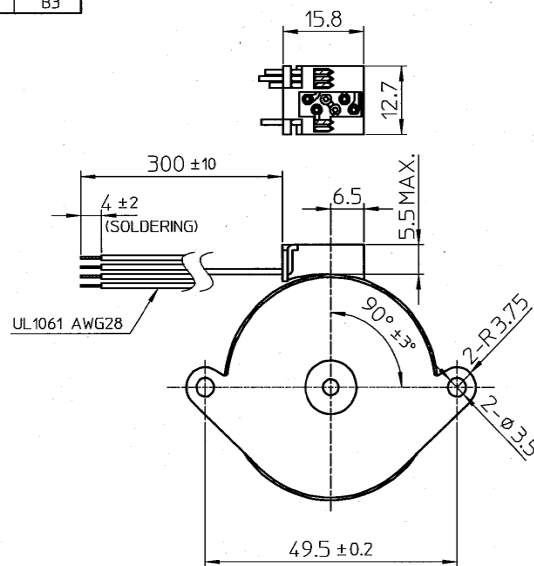

#### MARKING

NMB-MAT PM42S-048-HHC8
JAPAN H9817
<JAPAN>

NMB-MAT PM42S-048-HHC8
THAILAND TA9817
<THAILAND>

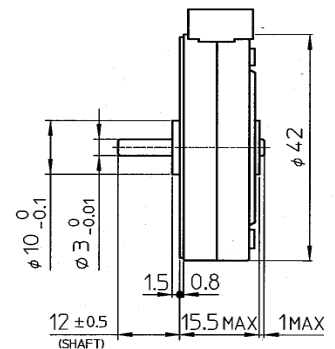



## Standard PM Step Motors

# PM42S-048-HHC8

### DYNAMIC TORQUE CHARACTERISTICS (No. 62794)

(ALL VALUES ARE GAINED BY MEASUREMENT AND NOT SPECIFICATIONS VALUES)

Model : PM42S-048-HHC8  
 Drive Mode : BIPOLAR CHOPPER  
 Drive Voltage : 24.0 V  
 Method : 2-2P  
 Drive IC : UDN2916B-V  
 Surge/Current : / 500 mA / Phase (Peak)  
 Coil Resistance : 8.0  $\Omega$   
 Magnet Material : MS70M  
 Stator Material : SECC

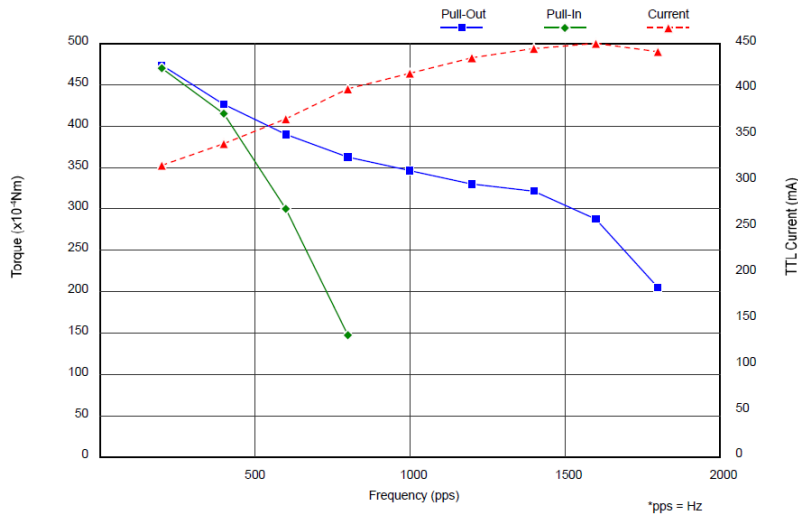

(TTL Current = Over all current drawn by the driver)

Frequency (pps)	200	400	600	800	1000	1200	1400	1600	1800
■ Pull-Out (x10 <sup>-4</sup> Nm)	472.7	425.6	389.3	361.9	345.2	329.5	320.7	286.4	204.0
◆ Pull-In (x10 <sup>-4</sup> Nm)	469.8	414.8	299.1	147.1					
▲ Current (mA)	317	340	367	400	417	434	444	449	441

Minebea Motor Manufacturing Corporation