

0.6A step-down DC-DC convertor IC

Monolithic IC MM3472

Outline

MM3472 series is a synchronous rectifying step-down DC/DC converter which is focused on space minimizing design, high oscillation frequency (2.25MHz) and high efficiency by fewer external components (1 coil and 2 capacitors) in order to meet miniaturization and low power consumption.

The package realizes space reduction of the mount area by mounting to the small SOT-26A and SSON-6L.

Features

- | | |
|-------------------------------------|--|
| (1) Input Voltage Range | 2.0V ~ 5.5V |
| (2) Output Voltage Range | 0.8V ~ 3.3V |
| (3) FB Voltage (PWM mode) | $V_{FB} \pm 1.5\%$ |
| (4) FB Voltage (PFM mode) | $V_{FB} \pm 2\%$ |
| (5) Output Current | 600mA |
| (6) Oscillation Frequency | 2.25MHz (typ.) |
| (7) Quiecent Current (Not swtching) | 11 μ A(typ.) |
| (8) Efficiency | ($V_{IN}=3.6V, V_{OUT}=1.8V$)
$I_o=0.01mA : 25\%$
$I_o=100mA : 90\%$ |
| (9) Protect Function | UVLO, Soft start, Current limit, Thermal shutdown |
| (10) PWM/PFM Control | Automatic |

Packages

- SOT-26A
- SSON-6L

Applications

- (1) Mobile Phone
- (2) Digital Still Cameras
- (3) Battery-Operating Devices

Block diagram

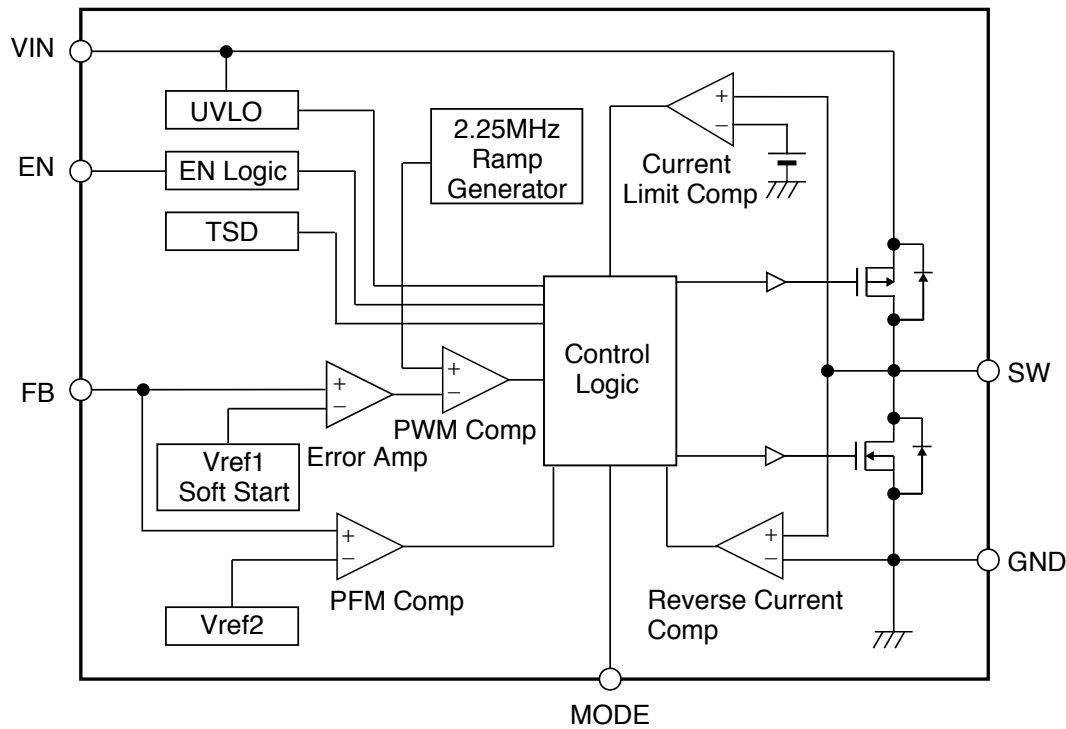

Pin description

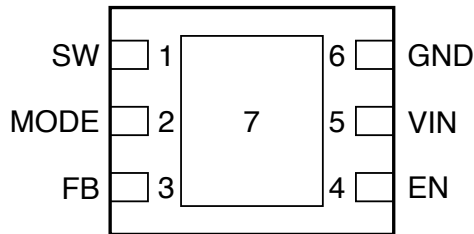

Top view

Pin No.	Symbol	Function
1	SW	Power switch pin
2	MODE	Mode pin (Pull below $GND+0.3V$ to operate automatic PWM/PFM mode control, Pull above $V_{IN}-0.3V$ to operate PWM mode only. Please avoid use in the state that is floating)
3	FB	Output voltage feedback pin
4	EN	Enable pin (Pull above $V_{IN} - 0.3V$ to enable, pull below $GND+0.3V$ to disable. Please avoid use in the state is floating.)
5	VIN	Power supply input pin
6	GND	Ground pin
7	TPAD	Thermal pad (Thermal pad must be connected to GND to use the best electrical characteristics.)

Absolute maximum rating

(Except where noted otherwise : Ta=25°C)

Item	Symbol	Rating	Unit
VIN power supply pin voltage	V _{IN}	-0.3 ~ +6.0	V
SW pin voltage	V _{SW}	-0.3 ~ V _{IN} +0.3 , 6.0	V
EN pin voltage	V _{EN}	-0.3 ~ +6.0	V
FB pin voltage	V _{FB}	-0.3 ~ +6.0	V
Storage temperature	T _{STG}	-55 ~ +150	°C
Power dissipation	Pd	~ 180 (Alone)	mW

Recommended Operation conditions

Item	Symbol	Condition	Unit
Operating ambient temperature	T _{OPR}	-40 ~ +85	°C
Operating voltage	V _{OPR}	2.0 ~ 5.5	V

Electrical characteristics

(Except where noted otherwise : $V_{IN}=V_{EN}=3.6V$, $V_{OUT}=1.8V$, $V_{MODE}=0V$, $T_a=25^\circ C$)

Item	Symbol	Measurment conditions	Min.	Typ.	Max.	Unit
Feed back voltage (PWM mode)	V_{FBPWM}		0.591	0.600	0.609	V
Feed back voltage (PFM mode)	V_{FBPFM}		0.588	0.600	0.612	V
Output voltage range	V_{OUTR}		0.8		3.3	V
Output voltage temperature characteristics * 1	$\Delta V_{OUT} / \Delta V$	$-40^\circ C \leq T \leq 85^\circ C$ (PWM mode)		± 100		ppm/ $^\circ C$
Supply current (No switching)	I_Q	$V_{IN}=3.6V$, $V_{FB}=0.8V$		11	17	μA
Shutdown current	I_{OFF}	$V_{EN}=GND$		0.1	1	μA
Highside Tr on resistance * 1	R_{ONH}	$V_{IN}=3.6V$, $I_{DS}=0.1A$		0.24		Ω
Lowside Tr on resistance * 1	R_{ONL}	$V_{IN}=3.6V$, $I_{DS}=0.1A$		0.20		Ω
Highside Tr current limit * 1	I_{LIN}			1.1		A
Osillation frequency	f_{osc}		2.0	2.25	2.50	MHz
EN pin high level voltage	V_{ENH}	V_{EN} is rising	$V_{IN} - 0.3$			V
EN pin low level voltage	V_{ENL}	V_{EN} is faling			GND+0.3	V
EN pin input current	I_{EN}	$V_{EN}=5.5V$		0.01	1	μA
MODE pin high level voltage	V_{MODEH}	V_{MODE} is rising	$V_{IN} - 0.3$			V
MODE pin low level voltage	V_{MODEL}	V_{MODE} is faling			GND+0.3	V
MODE pin input current	I_{MODE}	$V_{MODE}=5.5V$		0.01	1	μA
UVLO voltage	V_{UVLO}	V_{IN} is rising			2.0	V
UVLO hysteresis voltage	ΔV_{UVLO}			0.12		V
Soft start time	T_{SS}	$V_{EN}=0V$ to V_{IN}	0.15	0.3	0.6	ms
Thermal shutdown temperature * 1	T_{TSD}			140		$^\circ C$

(* 1) The parameter is quaranteed by design.

Measurement circuit

(Except where noted otherwise: $V_{IN}=V_{EN}=3.6V$, $V_{OUT}=1.8V$, $V_{MODE}=0V$, $T_a=25^{\circ}C$)

A.

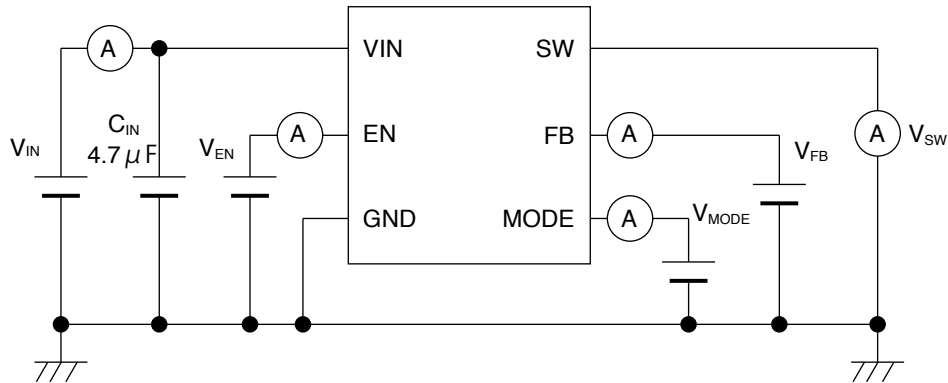

B.

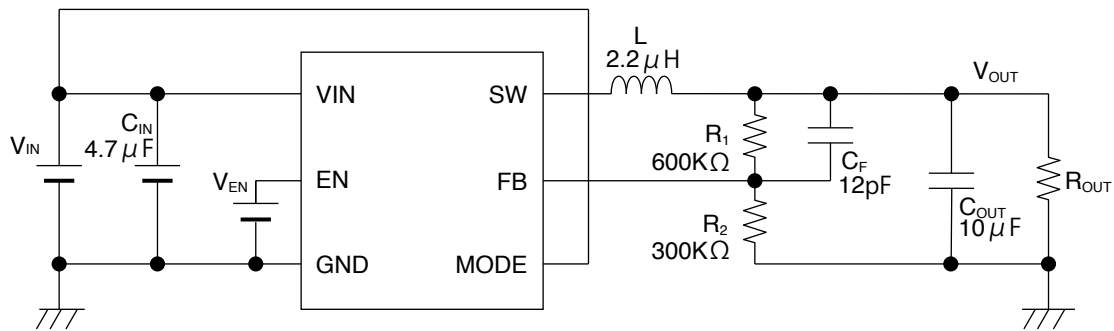

Timing chart

Start up operation

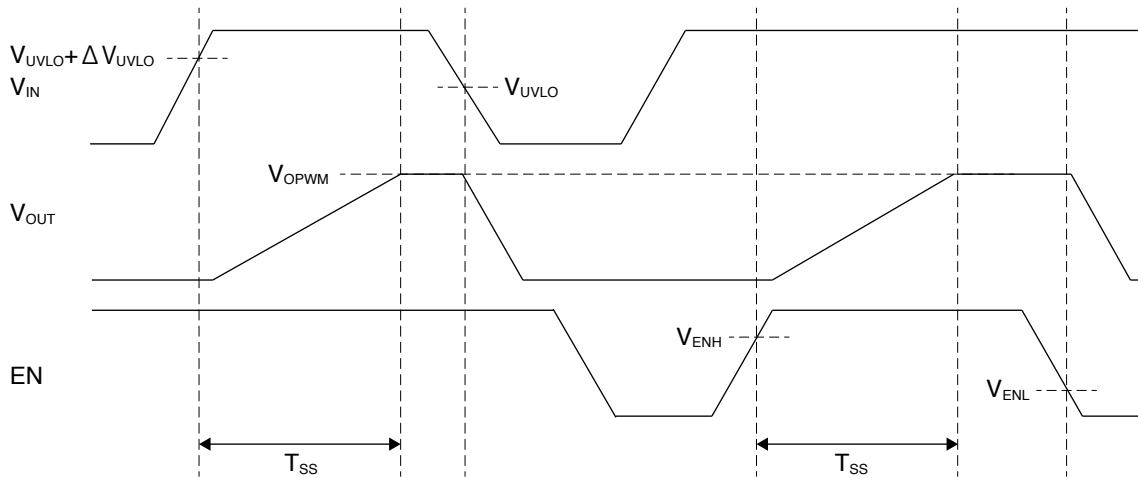

PWM/PFM mode operation

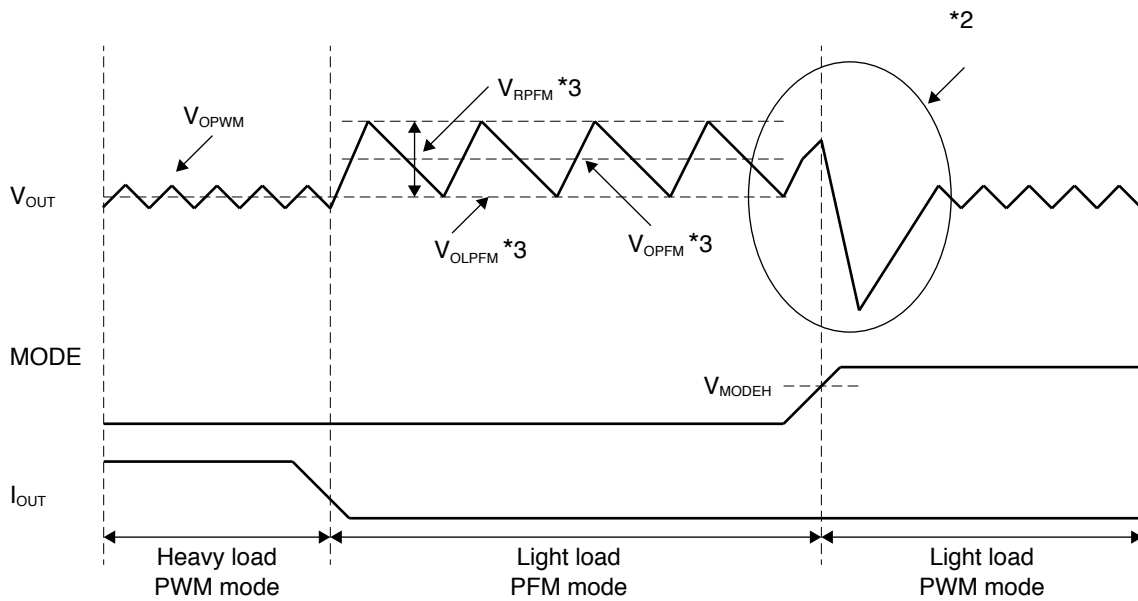

*2. Please note is there output uner-shoot at PFM-to-PWM transition.

*3. During PFM mode the average output voltage V_{OPFM} is added 0.5 times the ripple V_{RPFM} to the lower output voltage V_{OLPFM} . The V_{OLPFM} is calculated by the following equation.

$$V_{OLPFM} = V_{FBPFM} \times (R_1 + R_2) \div R_2$$

R_1 and R_2 is output feedback resistor, the V_{FBPFM} is feedback voltage during PFM mode.

Application circuit

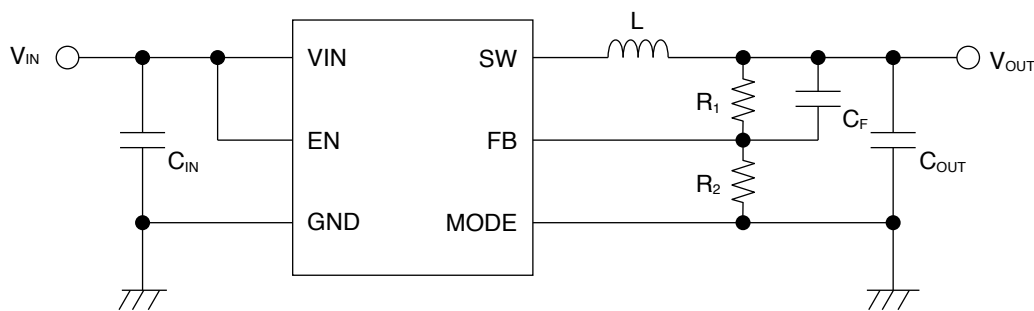

Recommend parts

Output voltage	Part					
	L	C _{IN}	C _{OUT}	R ₁	R ₂	C _F
0.8V	2.2 μH	4.7 μF	10 μF	100K Ω	300KΩ	12pF
1.2V				300K Ω		12pF
1.5V				450K Ω		12pF
1.8V				600K Ω		12pF
2.5V				950K Ω		8pF
3.3V				1.35M Ω		8pF

- L : 2.2 μH C3-P1.2RA (Mitsumi)
- C_{IN} : 4.7 μF GRM188R60J475KE19D (Murata)
- C_{OUT} : 10 μF GRM188R60J106KE47D (Murata)

Operating conditions

Output voltage	Input voltage	Maximum output current
0.8V	2.0V ≤ V _{IN} < 2.2V	0.3A
	2.2V ≤ V _{IN} ≤ 5.5V	0.6A
1.2V	2.0V ≤ V _{IN} < 2.2V	0.3A
	2.2V ≤ V _{IN} ≤ 5.5V	0.6A
1.5V	2.0V ≤ V _{IN} < 2.2V	0.15A
	2.2V ≤ V _{IN} < 2.4V	0.3A
	2.4V ≤ V _{IN} ≤ 5.5V	0.6A
1.8V	2.2V ≤ V _{IN} < 2.4V	0.15A
	2.4V ≤ V _{IN} < 2.6V	0.3A
	2.6V ≤ V _{IN} ≤ 5.5V	0.6A
2.5V	2.8V ≤ V _{IN} < 3.0V	0.15A
	3.0V ≤ V _{IN} < 3.2V	0.3A
	3.2V ≤ V _{IN} ≤ 5.5V	0.6A
3.3V	3.8V ≤ V _{IN} < 4.0V	0.15A
	4.0V ≤ V _{IN} < 4.2V	0.3A
	4.2V ≤ V _{IN} ≤ 5.5V	0.6A

Note : This current doesn't necessary guarantee to operate. Please evaluate the actual application to set the constant of external parts.

Characteristics

(Except where noted otherwise : Ta=25°C)

Efficiency

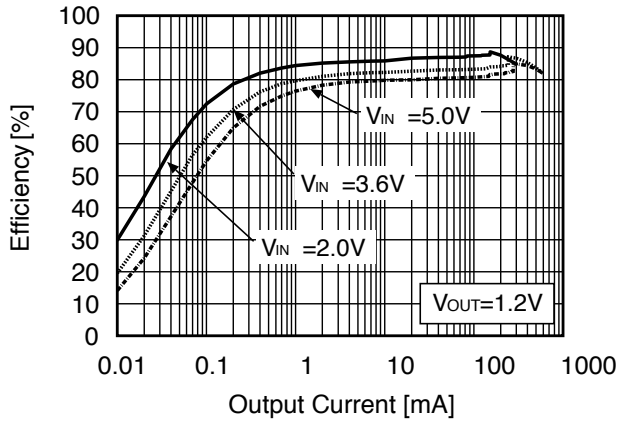

Efficiency

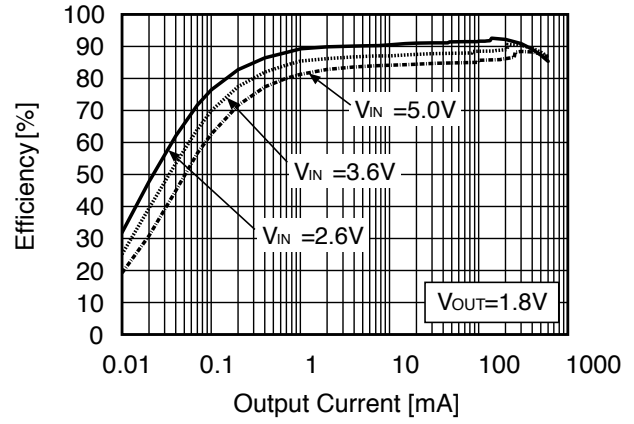

Efficiency

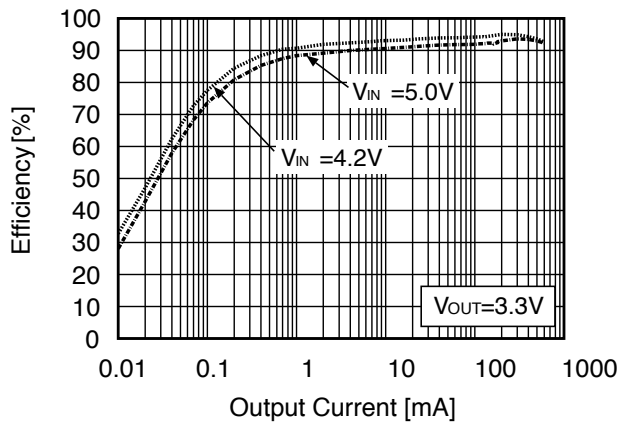

Load regulation

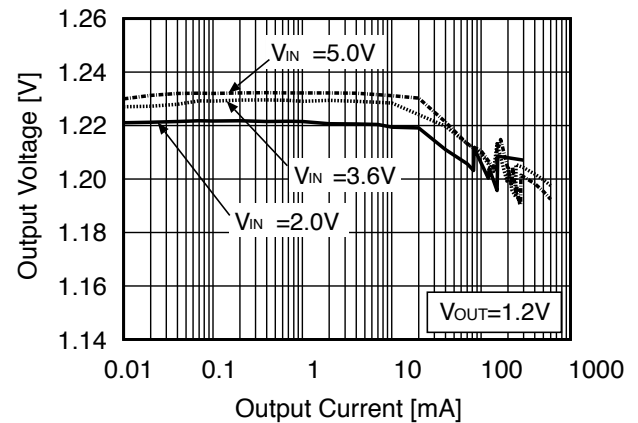

Load regulation

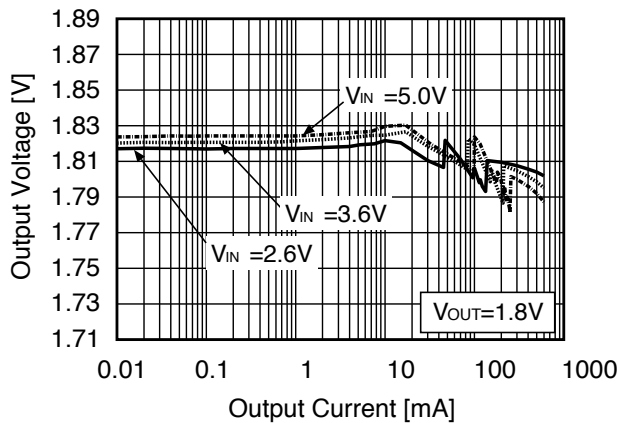

Load regulation

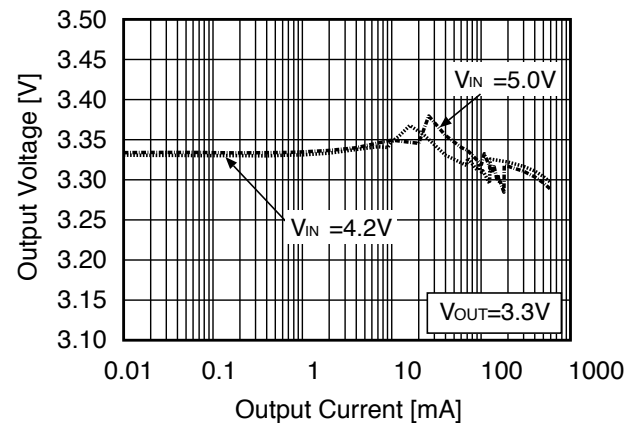

Line regulation

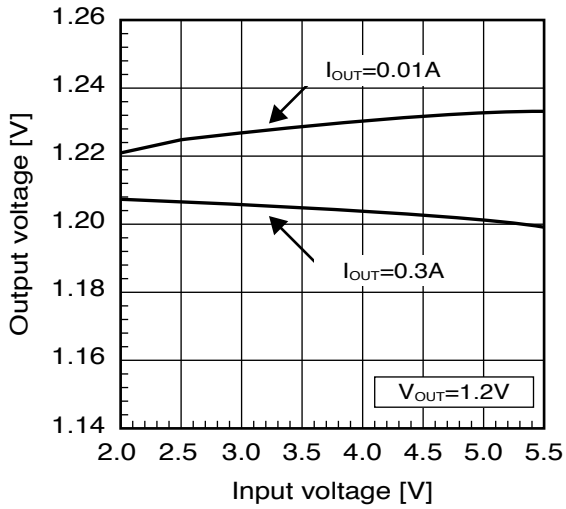

Line regulation

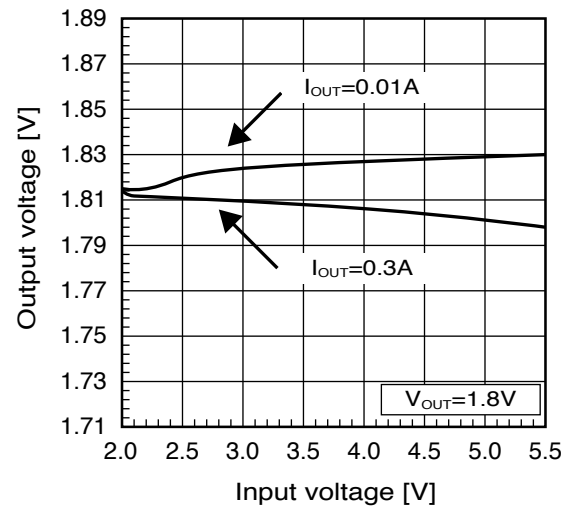

Line regulation

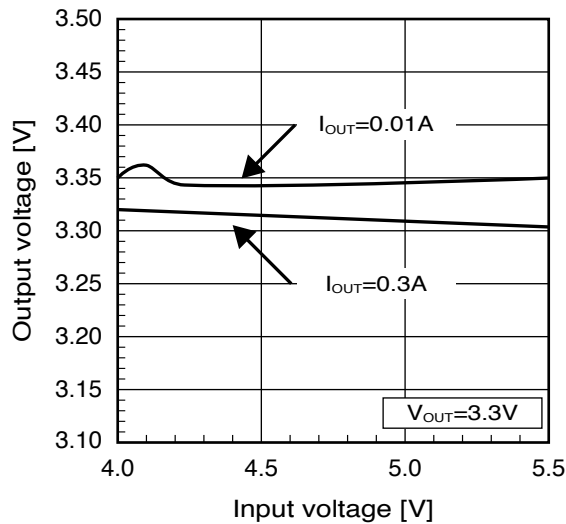

Start-up

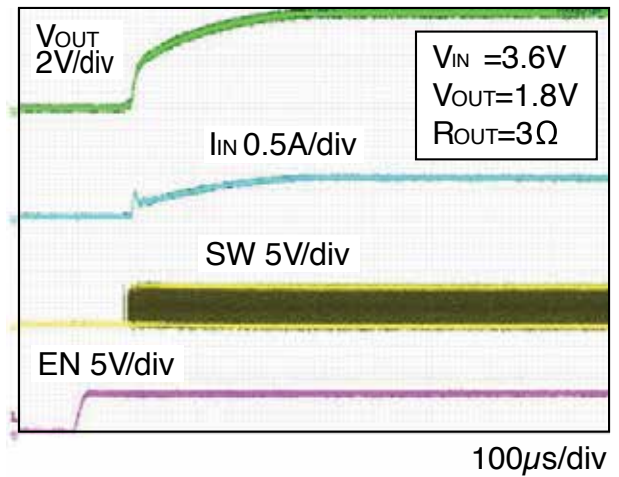

Load transient

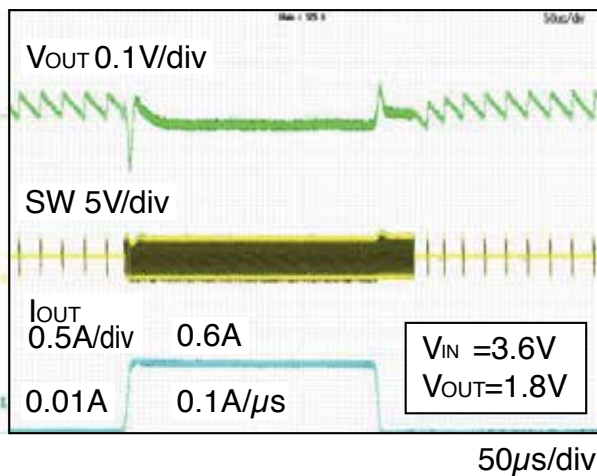

Load transient

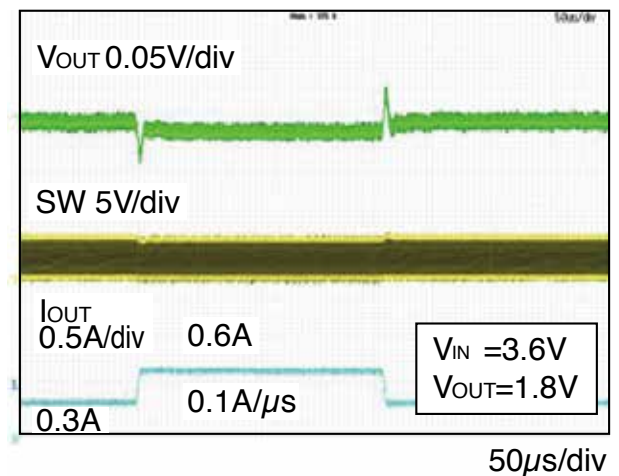

Load transient

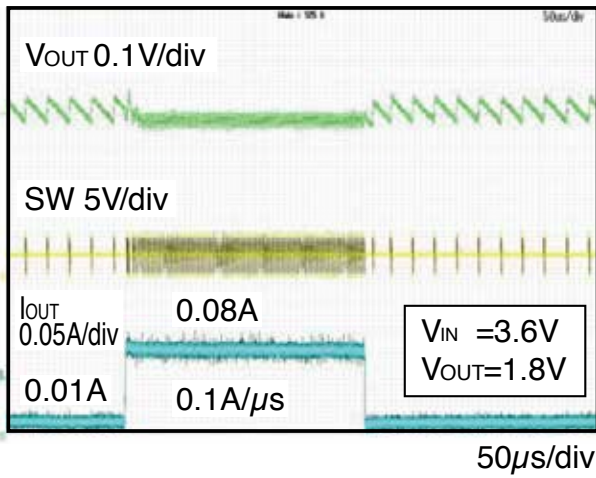

Line transient

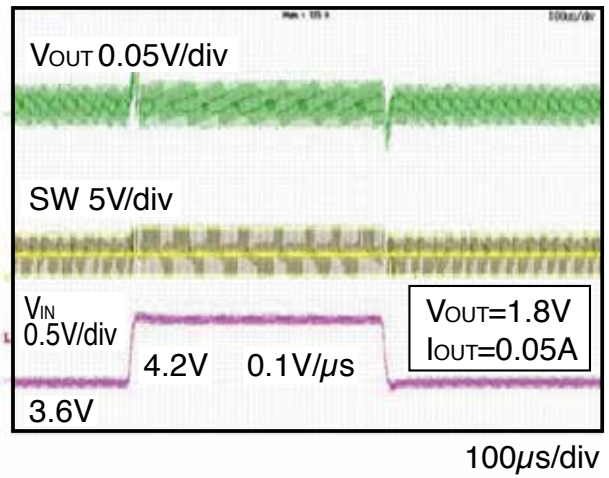

Line transient

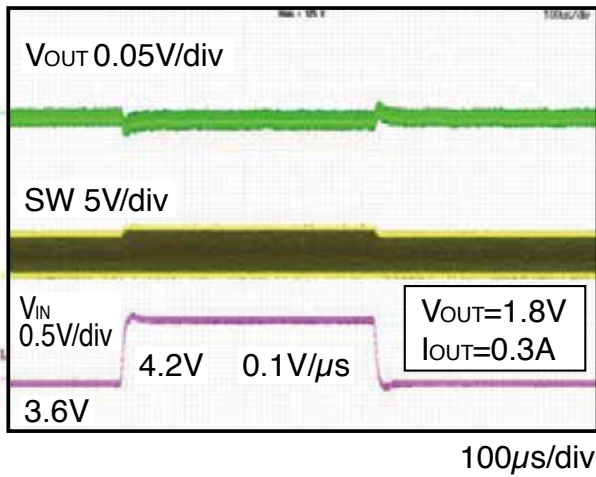

FB voltage (PWM)

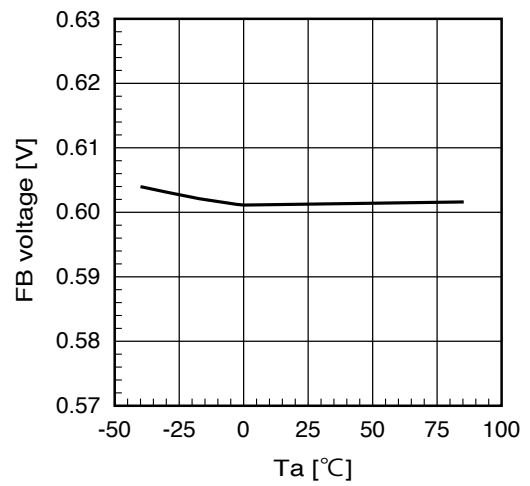

FB voltage (PFM)

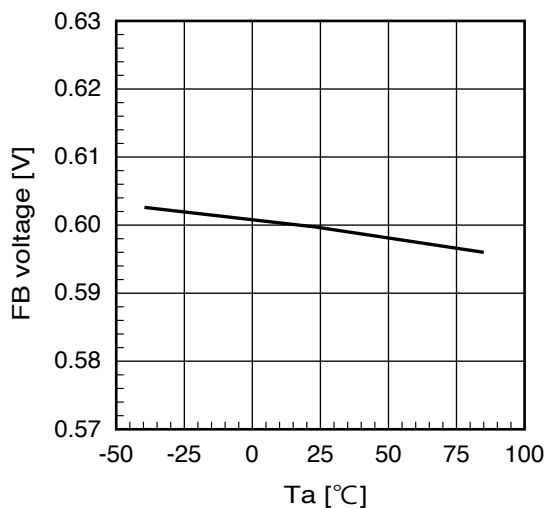

Oscillation frequency

